



# U62

# USER MANUAL

This product supports GPS positioning and is recommended for outdoor flight!  
This wifi camera pinpoint is 5G, please confirm whether the phone is supported.

- ▲ This product is suitable for users over 14 years old.
- ▲ Stay away from the rotating propeller
- ▲ Read the "important statement and safety guidelines" carefully.

# Ready before take off

## Drone preparation

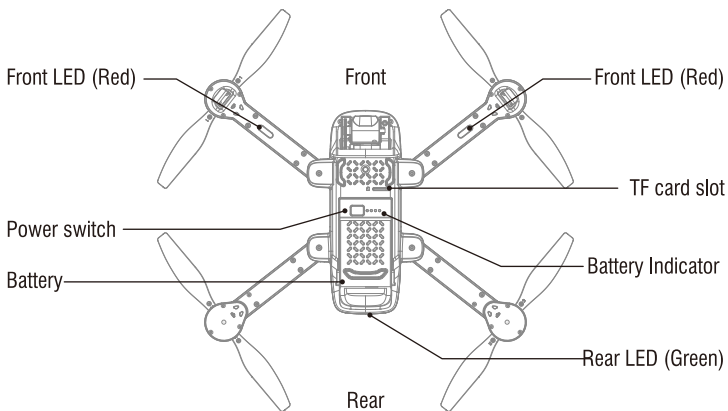
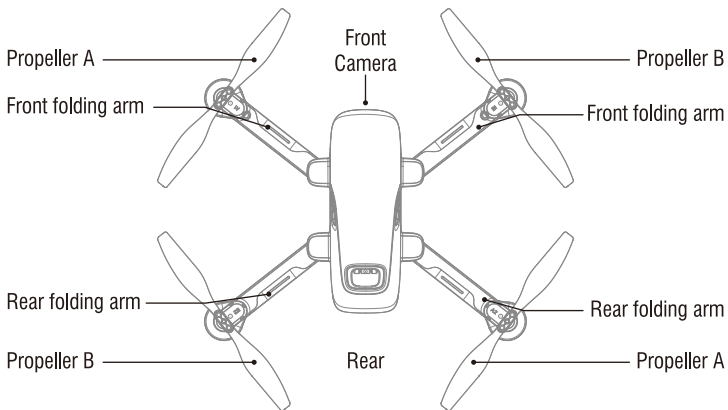

## Unfolding Instruction

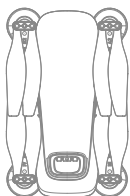

① Folding State

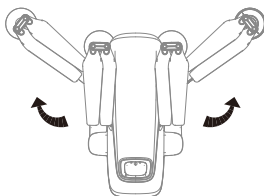

② Front folding arms unfold

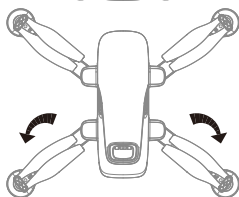

③ Rear folding arms unfold

## Battery Charger

Battery power is insufficient in the original plant. It must be charged saturated before it can be used.

Connect the batteries of the drone to the charging line of the original plant, and then connect to other USB charging sockets. Battery indicator flashes when charged. When the charging is completed, the battery indicator light is always on.

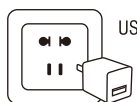

USB adapter (Not Include)

②

Original Charging Line

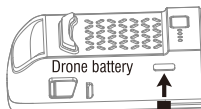

①

※ Only use the original charging line;  
Adapters with output current of  $5V \geq 2A$  must be selected.

## Battery Installation

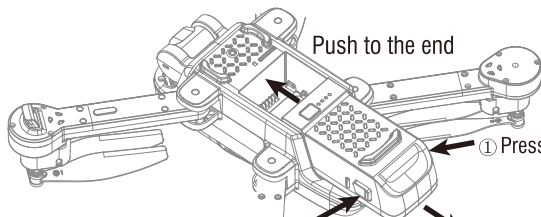

Push to the end

① Press to unlock the lock

① Press to unlock the lock

② Pull out the battery

## Installation of TF Card

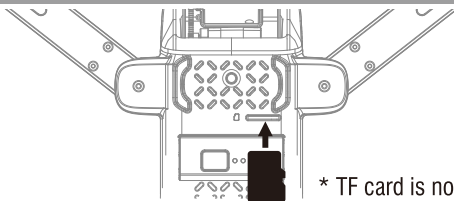

\* TF card is not included

Insert the TF card into the slot on the belly of the fuselage, and pay attention to the metal contact surface orientation of the TF card.

## Transmitter

The original transmitter is low in power, so it should be used after saturation.

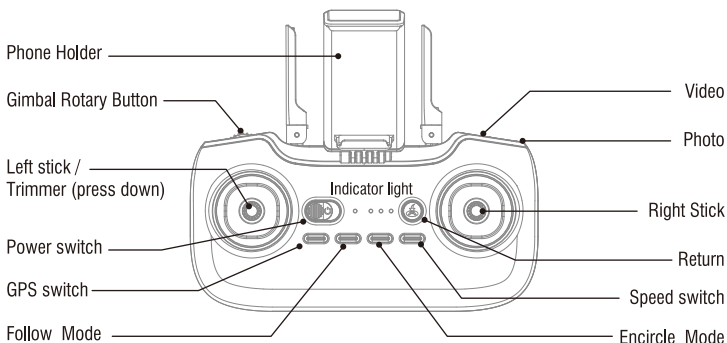

## Transmitter charging

**▲ Only use the original charging line;**  
**Adapters with output current of  $5V \geq 2A$  must be selected.**

Connect the transmitter with the charging line of the original plant, and then connect other USB charging outlets.

When charging, the transmitter indicator flashes circularly, and when charging is completed, the indicator will be on for a long time.

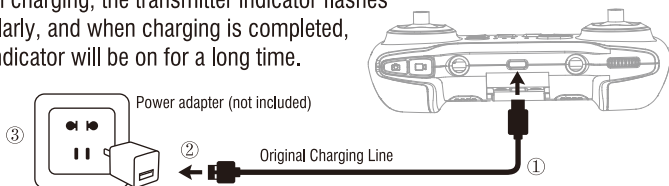

## The installation methods of mobile phone holder

### Installation

- ① Straightening the antenna

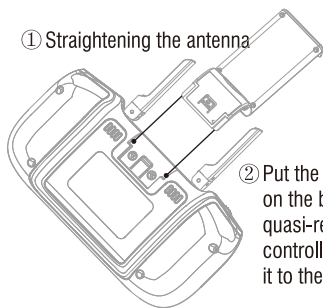

### Disassemble

- ② Pull up the clip on the mobile phone

- ① Press to unlock the lock



## The installation methods of mobile phone

- ① Pull up the clip on the mobile phone.

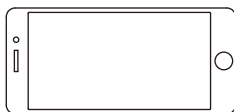
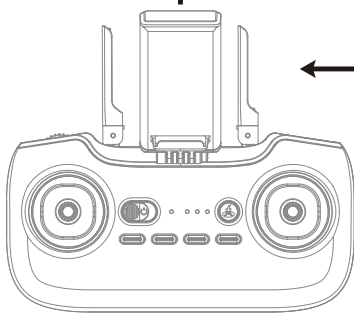

- ② Place the phone in the upper and lower clamps. Between the clamps, the clamp will automatically clamp the mobile phone.

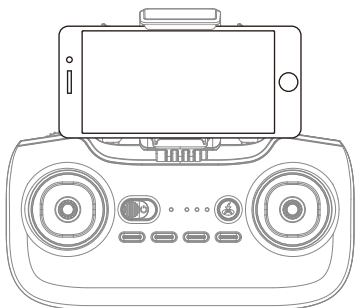

\* Notice: Don't clip the buttons on the side of the phone.

# Flight Operations

## Mobile phone connect with Drone

### Download and install APP: UDIGPS

This software is suitable for mobile phones in the IOS and Android system.

For detailed operation, please check the system "HELP" of APP.



## Transmitter connect with Drone

### Frequency Pairing

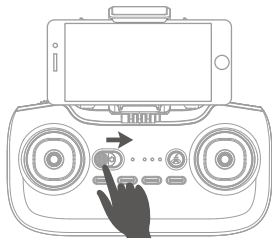

① Turn on the power.

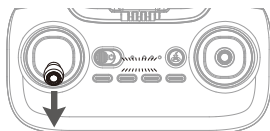

② Pull the left stick to the lowest position and let go, the light goes off slowly. it indicates the transmitter enters the frequency state.

③ The drone is placed on the horizontal ground, and long press the power button for 2 seconds to start the machine. After the navigation light is on for 2 seconds, the front navigation light flashes and the rear navigation light goes out. At the same time, the remote control emits a prompt sound of "di", indicating successful frequency alignment and entering the horizontal calibration of compass.

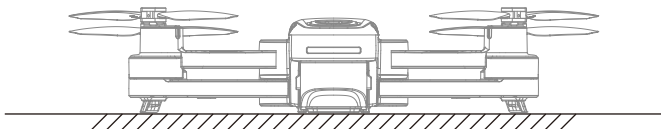

Horizontal ground

## Compass calibration

Rotate the drone horizontally until the transmitter sounds "di..." "Level correction to complete. When the front navigation light turns to long light and the rear navigation light flashes, enter vertical correction.

Rotate the drone vertically until the transmitter sounds "di..." A sound, vertical correction over. The lights are spinning and flashing.

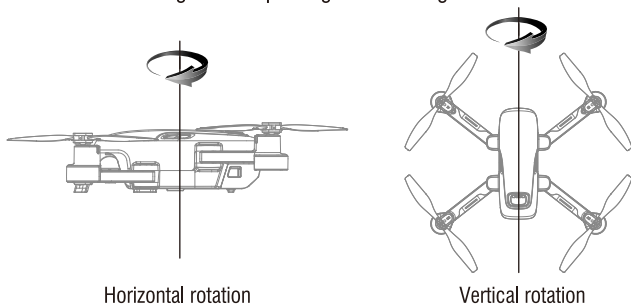

**Tips: It's a must to have the right compass adjustment first each time you start the drone, or it can't work normally**

## GPS signal search

After the frequency matching is successful, the drone automatically searches for GPS signals. When the blue indicator light of the remote control changes from flashing to long bright, it makes a sound of "di" at the same time, indicating that the GPS connection is successful. (when the GPS signal is weak or flying indoors, the flight height defaults to about 4 meters).

## Unlocking / Locking the motor

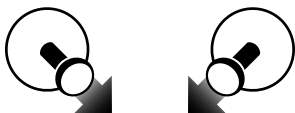

Push the left and right stick inward to the 45 degree angle simultaneously.

① On standby drone, motor rotation, drone Unlocked.

② When the drone is not take off, the motor stops rotating and the drone is locked.

**The drone can only take off when the motor is unlocked.**

# Control stick operation

## Left stick

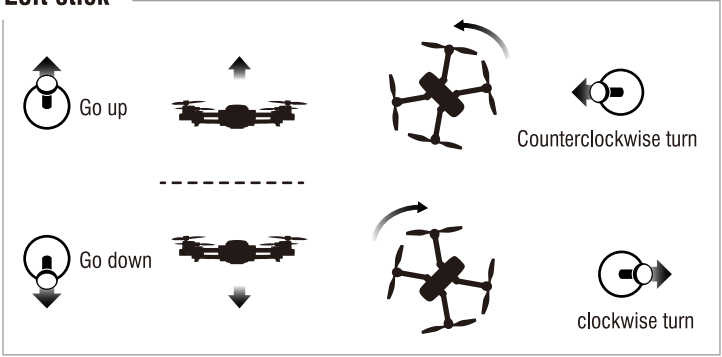

## Right Stick

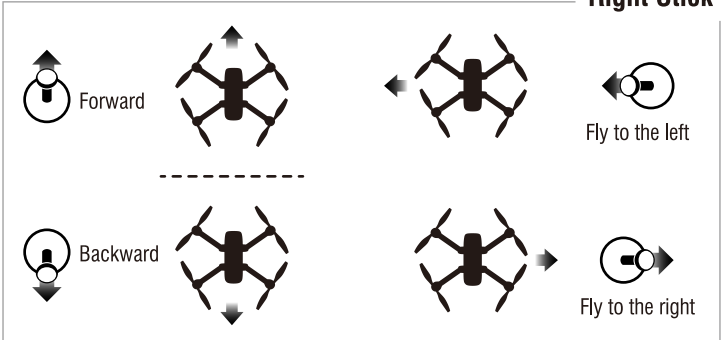

## Take off

After unlocking the motor, the left control lever slowly pushes up and the drone slowly rises.

## Landing

During the flight, the left control lever slowly pull down , and the drone slowly lands until landing.



## Return

During the flight, press the "return " button, and the transmitter will sound "di", and the drone will automatically return to the take-off point. (During returning, the transmitter will continuously sound "di". To stop homing, just press this button again.)

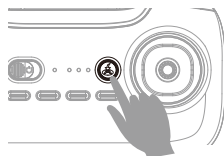

**Notice: While returning, the control lever of the transmitter can not control the drone, it must be waited for the drone to go back to the take-off point.**

**And after the direction of the drone is directed at the direction of taking off, in this way right stick can control the drone.**

## GPS ON /OFF

GPS is on by default.

GPS OFF: Press the "GPS "button ,the transmitter will sound "di"and the blue indicator of the transmitter will go off , it means GPS will be off.

GPS ON: Press the"GPS"button and the blue indicator of the transmitter will keep bright. It means GPS restart.

**Note: this function is only used when the motor is locked.**



## Following Function

While flying, press down the key, the transmitter sounds "di", drone enters the function of following.Now it can be controlled by the user.

The function is standard by the mobile phone APP signal, so it's a must to make the drone and App connected normally, turn on the mobile location service at the same time, otherwise this function is invalid.

**Note: follow the maximum range distance, within 300m of the take-off point.**



## Encircling flight

In flight, press the "encircle" button, and the transmitter will make the sound of "di". Then it goes to the function of encircling flight. The drone will fly to a default radius then it waits for the direction controlled by the user. Adjust the speed and direction of the drone by manipulating the right stick. It is the minimum radius of the default radius acquiescently, so drone flies only in the sub range.

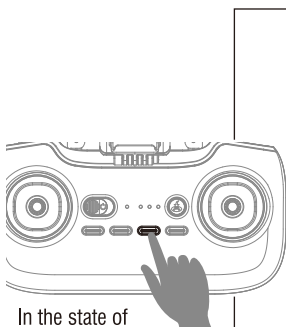

In the state of encircling flying, the left stick could only control the height of the drone.



Turn left, the drone flies clockwise; Move further, the flying speed will become faster.



Turn right, the drone flies counterclockwise; Move further, the speed will become faster.



Go upward to narrow the radius of encircling.



Go downside to enlarge the radius of encircling.

## Speed mode switch

Press "H/L" and make "Di. Di. Di" three times to enter high speed mode "H" ; Press it down again, it will make the sound "di" again, this indicates to the low speed mode "L";

Press down the key again, it makes the sound of 'di' for twice, it comes to the middle speed mode "M".

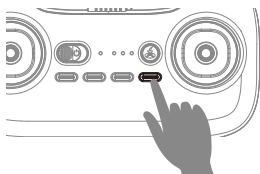

### Power on at default medium speed.

Low speed: suitable for beginners to practice without wind.

Medium speed: suitable for skilled operator operating in light breeze.

High speed: suitable for professional operation in outdoor wind resistance

## Gimbal Adjustment

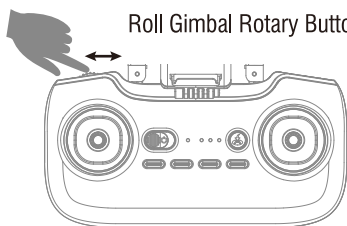

Tilting  $-90^{\circ}$  to  $0^{\circ}$



## Photo

Press the "photo" button once to take a picture.

**When taking photos, the transmitter will send out a "di" sound.**

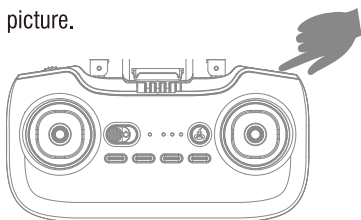

## Video

Press the "video" button to enter the recording state, and the transmitter will prompt "didi" to repeat this action to stop recording and save video.



## Notes for Filming

- ① Photos taken will be saved to mobile picture library and aircraft TF card; Video can be saved in TF card first, which can be downloaded to mobile picture library for viewing. Please download video according to APP prompt. When downloading, maintain the normal connection between the mobile phone and the flyer, and the TF card is in the card slot.
- ② The APP must be authorized to read the phone gallery to view the aerial photos.
- ③ Turn off the power supply of the drone before taking out the TF card.
- ④ When aerial video is read by computer, it must have corresponding playback software.

## Intelligent Hover

Intelligent flight control can calculate the suspended height, the visual system points the ground position, GPS coordinates allow the vehicle to stay in your desired position. The drone is like a camera fixed in the air. Aerial photography and control are very convenient.

**Notice: Drone must be connected to GPS properly in order to give full play to fixed-point hovering function. Atmospheric pressure or wind force affects hovering stability.**

## Low Battery Alarm

When the battery power of the point remote is quickly exhausted, it will make the sound of “di” “di” “di” constantly to alarm you, now you should land the drone as soon as possible to charge the battery.

## Automatic Return

While flying, in case that the battery of the drone is quickly exhausted, it will make the sound of “di” “di” to alarm you, the drone's indicator lights turn from long to bright. After alarming you, the drone automatically returned to the take-off point.

**Notice: After low-battery alarm, the drone will return home. Meanwhile, its controllable range will be reached to the 20 meter**

## Out of Range Alarm

When the drone flying out of the max remote control distance, the transmitter will beep “didi...didi...didi...” to alarm the user to fly back the drone within range immediately.

## Stuck Protection

1. When the propeller is stuck and does not rotate, the drone will start the automatic protection function to stop the motor working.
2. Reset the left stick to the lowest position and return to the middle position, at this time the LED light keeps bright to unlock protection function automatically, then the drone can take off normally.

## Out of Control Protection

Out of control protection refers to the flight control system automatically controls the drone to fly back to the return point after receiving the remote control signal (ie, out of control), the drone does not have the function of avoiding obstacles during the uncontrolled return flight. The user can set the return altitude value to avoid obstacles on the way back.

### Possibility of entry into runaway protection mode

- \* The remote control is off.
- \* Flight distance exceeds the effective distance of remote control signal transmission.
- \* There is an obstacle between the transmitter and the drone.
- \* Transmitter signal is disturbed.

## Flying Trimmer



### Forward / Backward Trimmer

When flying, if the drone tilts forward, push the left stick down and push the right stick down. Otherwise push it up



### Left / Right Tilts Trimmer

When flying, if the drone tilts to the left, push the left stick down, meantime push the right stick to the right. Otherwise push it to the left.



### Left / Right Rotates Trimmer

When flying, if the drone head rotates to the left, push the right stick down, meantime push left stick to right. Otherwise push it to the left.

## Gyroscope Calibration

After the calibration of the compass, the right control lever of the remote control is pushed to the lower right corner by 45°, and the remote control will sound of "di", and the aircraft light flashes and releases, indicating that the gyroscope has been calibrated. (drone should be placed on horizontal ground)



**Tips:** When the drone doesn't appear to use the trim correction flight status, or being hit hard (or falling abnormally). thus cause the difficulties in controlling. Now frequency making and adjustment are needed again.

## Propeller replacement

**Disassembly:** First screw out the screw then pull out the propeller.

**Installation:** Make sure that the propeller aims at the hole direction of the drone hole then press it down to the bottom and lock the screw.

**Note:** There are marked "A" and "B" on the back of the propeller. Please carefully check the letters "A" and "B" on the folding arm of the drone. The two letters must correspond to each other during installation.

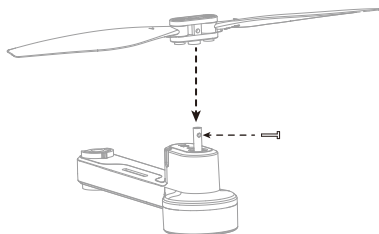

## Attention

- ① Switching sequence. At first, turn on the power of the transmitter, then turn on the power of the drone. After the end, turn off the power of the drone first, and then turn off the power of the transmitter.
- ② Improper operation caused the crash. It is necessary to check and confirm the connection of the motor, blade or electric pool of the aircraft and the damage degree, so that the aircraft can fly again. If it is damaged, please replace it with new accessories, otherwise it will easily cause flight accidents.
- ③ Battery must be removed when the drone is not in use.



### Drone Battery Li-Po Battery Disposal & Recycling

Wasted Lithium-Polymer batteries must not be placed with household trash. Please contact local environmental or waste agency or the supplier of your model or your nearest Li-Po battery recycling center.



### Important Notice

Our company's products are improving all the time, design and specifications are subject to change without notice.

All the information in this manual has been carefully checked to ensure accuracy, if any printing errors, our company reserve the final interpretation right.

# Parameter

## Drone

Weight: 270g (Include battery)

Size: Folded: 150\*96\*60mm  
Diagonal: 263\*263\*60mm

Propeller diameter: 155mm

Maximum ascent rate: 1.7m/s

Maximum descent rate: 1.7m/s

Maximum speed: About 20km/h

Flight altitude limit: 250m

Maximum flight time: 17 minutes(calm)

Maximum wind speed: level 3

Maximum tilt angle: 35°

Operating Temperature Range: 0°C to 40°C

GNSS: GPS/GLONASS

Operating frequency: 2.4Ghz /5G wifi

## Gimbal

Stable: Single axis (tilt)

Controllable range: Tilting: -90° to 0°

## Camera

Image resolution: 2048x1152P

Static Photography Mode: Single shoot

Video Resolution: 2048\*1152P

Image mode: RGB Mode

Frame Rate: 25

File System Support: FAT 32

Image format: JPEG format

Video format: MP4 Compressed  
format H.264

TF Card: Support Class 10 Micro  
TF card, Supreme support 64G.  
≥10 level Micro TF Card.

Operation Temperature: 0°C to 40°C

Tips: the above data are the test data of UDIRC toy lab, for reference only.

## **Drone Battery**

Capacity: 1500mAh

Voltage: 7.4V

Type of battery: LiPo

Energy: 11.1Wh

Net Weight: about 82g

Charging temperature range: 5°C to 40°C

## **Transmitter**

Operation Frequency: 2.4Ghz

Maximum transmission distance: 300m

Operating Temperature: 0°C to 40°C

Battery: 3.7V, 1200mAh

Mobile device bracket: Suitable for smartphones

## **Charger**

Input: 5V  $\geq$  2A

## **APP**

App Name: UDIGPS

Image transmission system: 5G wifi

Real time image transmission: 720 P@20 fps

Operation System: This software is suitable for mobile phones in the IOS 9.0 or later and Android 4.4 or later system,

Tips: the above data are the test data of UDIRC toy lab, for reference only.



# Troubleshooting

Problem	Problem cause	Solution
The controller Indicator light is off.	Low battery.	Charge the drone battery.
	The batteries are incorrectly.	Install the batteries following the polarity indicators.
	The batteries are incorrectly positioned.	Clean the dirt between the battery and the battery contacts.
Failed to pair the drone with the controller.	Indicator light is off.	The same as above.
	There is an interfering signal nearby.	Restart the drone and power on the controller.
	Mis-operation.	Operate the drone step by step in accordance with the user manual.
	The electronic component is damaged for fiercely crash.	To buy spare parts from local seller and replace damaged parts.
The drone is under-powered or can not fly.	The propeller is seriously deformed.	Replace the propeller.
	Low battery.	Charge the drone battery.
	Incorrect installation of propeller.	Install the propeller in accordance with the user manual.
	Motor is damage.	Replace the motor.
The drone could not hover and tilts to one side.	Improper Calibration.	Please refer to the Calibration.
	The propeller is seriously.	Replace the propeller.
	The motor holder is deformed after violent crash.	Replace the motor holder parts.
	The gyroscope did not reset after a serious crash.	Put the drone on the flat ground for about 10 minutes or restart the drone to calibrate again.
The drone indicator light is off.	Low battery.	Recharge the drone battery.
	The battery is expired or over discharge protection.	Buy a new battery from local seller to replace the battery or charge the battery.
	Poor contact	Connect and disconnect the battery.
Could not see the picture.	There is an interfering signal nearby.	Practice and read the cellphone controlling instruction carefully.
	Camera is damaged.	Replace Camera.
Hard to control by cellphone.	Not experienced enough.	Practice and read the cellphone controlling instruction carefully.
Can't altitude hold.	The propeller is seriously.	Replace propeller.
	Atmospheric pressure is not stable.	Refer to "Altitude Hold Mode" instruction.
Can't position hold.	Whether the GPS has connected or not.	Search again to connect the GPS signal.
	Optical flow board is damaged.	Please replace a new one.
Searchedbut could not find the GPS signal.	GPS module is damaged.	Please replace a new one.
	GPS module plug is loose.	Please check to see if it's connected normally.

## FCC Note

This equipment has been tested and found to comply with the limits for a Class B digital device, pursuant to Part 15 of the FCC Rules. These limits are designed to provide reasonable protection against harmful interference in a residential installation. This equipment generates uses and can radiate radio frequency energy and, if not installed and used in accordance with the instructions, may cause harmful interference to radio communications. However, there is no guarantee that interference will not occur in a particular installation. If this equipment does cause harmful interference to radio or television reception, which can be determined by turning the equipment off and on, the user is encouraged to try to correct the interference by one or more of the following measures:

- Reorient or relocate the receiving antenna.
- Increase the separation between the equipment and receiver.
- Connect the equipment into an outlet on a circuit different from that to which the receiver is connected.

**WARNING: Changes or modifications not expressly approved by the party responsible for compliance could void the user's authority to operate the equipment.**

## FCC Notice:

The equipment may generate or use radio frequency energy. Changes or modifications to this equipment may cause harmful interference unless the modifications are expressly approved in the instruction manual. Modifications not authorized by the manufacturer may void user's authority to operate this device.

This device complies with Part 15 of the FCC Rules. Operation is subject to the following two conditions:

- (1) This device may not cause harmful interference.
- (2) This device must accept any interference received, including interference that may cause undesired operation.

## FCC Radiation Exposure Statement

The device has been evaluated to meet general RF exposure requirement.  
The device can be used in portable exposure condition with out restriction.



**Manufacturer company: SHANTOU CITY CHENGHAI UDIRC TOYS CO., LTD**

Manufacture address: Guangfeng Industrial Zone, Guangyi Street, Chenghai District, Shantou City, Guangdong Province, China

Model: U62

Manufacture time:

**MADE IN CHINA**